



INTERNATIONAL APPLICATION PUBLISHED UNDER THE PATENT COOPERATION TREATY (PCT)

(51) International Patent Classification <sup>6</sup> : E04F 15/04, F16B 5/00	A1	(11) International Publication Number: <b>WO 97/47834</b> (43) International Publication Date: 18 December 1997 (18.12.97)
--	----	---

(21) International Application Number: PCT/EP97/03006

(22) International Filing Date: 7 June 1997 (07.06.97)

(30) Priority Data:  
9600527 11 June 1996 (11.06.96) BE  
9700344 15 April 1997 (15.04.97) BE

(71) Applicant: UNILIN BEHEER B.V. [NL/NL]; Hoogeveeneweg 28, NL-2913 LV Nieuwerkerk aan de IJssel (NL).

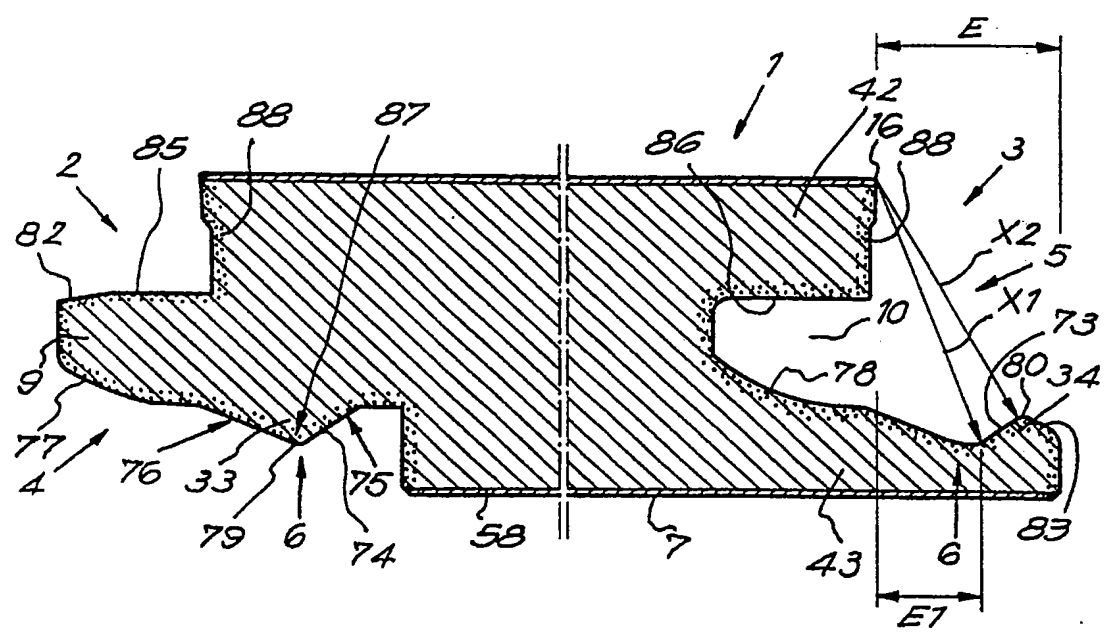
(72) Inventors: MORIAU, Stefan, Simon, Gustaaf; Koningin Fabiolalaan 39, B-9000 Gent (BE). CAPPELLE, Mark, Gaston, Maurits; Cardijnlaan 8, B-8840 Staden (BE). THIERS, Bernard, Paul, Joseph; Stationsstraat 134, B-8780 Oostrozebeke (BE).

(74) Agent: DONNÉ, Eddy; Bureau M.F.J. Bockstael N.V., Arenbergstraat 13, B-2000 Antwerpen (BE).

(81) Designated States: AL, AM, AT, AU, AZ, BA, BB, BG, BR, BY, CA, CH, CN, CU, CZ, CZ (Utility model), DE, DK, DK (Utility model), EE, EE (Utility model), ES, FI, FI (Utility model); GB, GE, HU, IL, IS, JP, KE, KG, KP, KR, KZ, LC, LK, LR, LS, LT, LU, LV, MD, MG, MK, MN, MW, MX, NO, NZ, PL, PT, RO, RU, SD, SE, SG, SI, SK, SK (Utility model), TJ, TM, TR, TT, UA, UG, UZ, VN, YU, ARIPO patent (GH, KE, LS, MW, SD, SZ, UG), Eurasian patent (AM, AZ, BY, KG, KZ, MD, RU, TJ, TM), European patent (AT, BE, CH, DE, DK, ES, FI, FR, GB, GR, IE, IT, LU, MC, NL, PT, SE), OAPI patent (BF, BJ, CF, CG, CI, CM, GA, GN, ML, MR, NE, SN, TD, TG).

**Published**  
*With international search report.*

(54) Title: FLOOR COVERING, CONSISTING OF HARD FLOOR PANELS AND METHOD FOR MANUFACTURING SUCH FLOOR PANELS



(57) Abstract

Floor covering, consisting of hard floor panels (1) which, at least at the edges of two opposite sides (2-3, 26-27), are provided with coupling parts (4-5, 28-29), cooperating with each other, substantially in the form of a tongue (9-31) and a groove (10-32), characterized in that the coupling parts (4-5, 28-29) are provided with integrated mechanical locking means (6) which prevent the drifting apart of two coupled floor panels into a direction (R) perpendicular to the related edges (2-3, 26-27) and parallel to the underside (7) of the coupled floor panels (1).

*FOR THE PURPOSES OF INFORMATION ONLY*

Codes used to identify States party to the PCT on the front pages of pamphlets publishing international applications under the PCT.

AL	Albania	ES	Spain	LS	Lesotho	SI	Slovenia
AM	Armenia	FI	Finland	LT	Lithuania	SK	Slovakia
AT	Austria	FR	France	LU	Luxembourg	SN	Senegal
AU	Australia	GA	Gabon	LV	Latvia	SZ	Swaziland
AZ	Azerbaijan	GB	United Kingdom	MC	Monaco	TD	Chad
BA	Bosnia and Herzegovina	GE	Georgia	MD	Republic of Moldova	TG	Togo
BB	Barbados	GH	Ghana	MG	Madagascar	TJ	Tajikistan
BE	Belgium	GN	Guinea	MK	The former Yugoslav Republic of Macedonia	TM	Turkmenistan
BF	Burkina Faso	GR	Greece			TR	Turkey
BG	Bulgaria	HU	Hungary	ML	Mali	TT	Trinidad and Tobago
BJ	Benin	IE	Ireland	MN	Mongolia	UA	Ukraine
BR	Brazil	IL	Israel	MR	Mauritania	UG	Uganda
BY	Belarus	IS	Iceland	MW	Malawi	US	United States of America
CA	Canada	IT	Italy	MX	Mexico	UZ	Uzbekistan
CF	Central African Republic	JP	Japan	NE	Niger	VN	Viet Nam
CG	Congo	KE	Kenya	NL	Netherlands	YU	Yugoslavia
CH	Switzerland	KG	Kyrgyzstan	NO	Norway	ZW	Zimbabwe
CI	Côte d'Ivoire	KP	Democratic People's Republic of Korea	NZ	New Zealand		
CM	Cameroon		Republic of Korea	PL	Poland		
CN	China	KR	Republic of Korea	PT	Portugal		
CU	Cuba	KZ	Kazakstan	RO	Romania		
CZ	Czech Republic	LC	Saint Lucia	RU	Russian Federation		
DE	Germany	LI	Liechtenstein	SD	Sudan		
DK	Denmark	LK	Sri Lanka	SE	Sweden		
EE	Estonia	LR	Liberia	SG	Singapore		

Floor covering, consisting of hard floor panels and method for manufacturing such floor panels.

---

5 This invention relates to a floor covering, consisting of hard floor panels, as well as to a method for manufacturing such floor panels.

10 In first instance, the invention is intended for so-called laminated floors, but generally it can also be applied for other kinds of floor covering, consisting of hard floor panels, such as veneer parquet, prefabricated parquet, or other floor panels which can be compared to laminated floor.

15

It is known that such floor panels can be applied in various ways.

20 According to a first possibility, the floor panels are attached at the underlying floor, either by glueing or by nailing them on. This technique has as a disadvantage that it is rather complicated and that subsequent changes can only be made by breaking out the floor panels.

25 According to a second possibility, the floor panels are installed loosely onto the underground, whereby the floor panels mutually match into each other by means of a tongue and groove coupling, whereby mostly they are glued together in the tongue and groove, too. The floor  
30 obtained in this manner, also called a floating parquet flooring, has as an advantage that it is easy to install and that the complete floor surface can move which often is convenient in order to receive possible expansion and shrinkage phenomena.

35

A disadvantage with a floor covering of the above-

mentioned type, above all, if the floor panels are installed loosely onto the underground, consists in that during the expansion of the floor and its subsequent shrinkage, the floor panels themselves can drift apart, as a result of which undesired joints can be formed, for example, if the glue connection breaks.

In order to remedy this disadvantage, techniques have already been thought of whereby connection elements made of metal are provided between the single floor panels in order to keep them together. Such connection elements, however, are rather expensive in manufacturing them and, furthermore, their provision or the installation thereof is a time-consuming occupation.

Examples of embodiments which apply such metal connection elements are described, among others, in the documents WO 94/26999 and WO 93/13280.

Furthermore, couplings are known which allow to snap floor parts into each other, a.o. from the documents WO 94/1628, WO 96/27719 and WO 96/27721. The snapping-together effect obtained with these forms of embodiment, however, does not guarantee a 100-percent optimum counteraction against the development of gaps between the floor panels, more particularly, because in fact well-defined plays have to be provided in order to be sure that the snapping-together is possible.

From GB 424.057, a coupling for parquetry parts is known which, in consideration of the nature of the coupling, only is appropriate for massive wooden parquetry.

Furthermore, there are also couplings for panels known from the documents GB 2.117.813, GB 2.256.023 and DE 3.544.845. These couplings, however, are not appropriate

for connecting floor panels.

The invention aims at an improved floor covering of the  
aforementioned type, the floor panels of which can be  
5 coupled to each other in an optimum manner and/or the  
floor panels of which can be manufactured in a smooth  
manner, and whereby preferably one or more of the  
aforementioned disadvantages are excluded.

10 The invention also aims at a floor covering which shows  
the advantage that no mistakes during installing, such as  
gaps and such, can be created.

Furthermore, the invention also aims at a floor covering  
15 whereby the subsequent development of gaps is excluded or  
at least counteracted in an optimum manner, whereby also  
the possibility of the penetration of dirt and humidity  
is minimized.

20 To this aim, the invention relates to a floor covering,  
consisting of hard floor panels which, at least at the  
edges of two opposite sides, are provided with coupling  
parts, cooperating with each other, substantially in the  
form of a tongue and a groove, characterized in that the  
25 coupling parts are provided with integrated mechanical  
locking means which prevent the drifting apart of two  
coupled floor panels into a direction perpendicular to  
the related edges and parallel to the underside of the  
coupled floor panels. Hereby, these coupling parts are  
30 optimized in such a manner that they allow that any  
form of play is counteracted and preferably is excluded.

By integrated mechanical locking means is understood that  
these form a fixed part of the floor panels, either by  
35 being connected in a fixed manner to the floor panels, or  
by being formed in one piece herewith.

In a first important preferred form of embodiment, the coupling parts are provided with locking means which, in the engaged position of two or more of such floor panels, exert a tension force upon each other which force the floor panels towards each other. As a result of this is effected that not only during installing the formation of gaps is counteracted, but also in a later stage the development of gaps, as a result of which causes whatsoever, is counteracted.

According to another characteristic of the invention, the coupling parts, hereby, are realized in one piece with the core of the floor panels.

According to a second important preferred form of embodiment, the aforementioned optimalization consists in that the floor covering shows the following combination of characteristics: that the coupling parts and locking means are realized in one piece with the core of the floor panels; that the coupling parts have such a shape that two subsequent floor panels can be engaged into each other exclusively by snapping together and/or turning, whereby each subsequent floor panel can be inserted laterally into the previous; that the coupling parts provide in an interlocking, free from play, according to all directions in the plane which is situated perpendicular to the aforementioned edges; that the possible difference between the upper and lower lip of the lips which border the aforementioned groove, measured in the plane of the floor panel and perpendicular to the longitudinal direction of the groove, is smaller than one time the total thickness; that the total thickness of each related floor panel is larger than or equal to 5 mm; and that the basic material of the floor panels, of which the aforementioned core and locking means are formed, consists of a ground product which, by means of a

binding agent or by means of melting together, is composed to a single compound, and/or of a product on the basis of synthetic material and/or of a chip board with fine chips.

5

Due to the fact that the coupling parts provide for an interlocking free from play, as well as due to the fact that these coupling parts are manufactured in one piece, from the basic material of the floor panels, a perfect connection between adjacent floor panels can always be guaranteed, even with repeated expansion and shrinkage of the floor surface.

10

This combination of characteristics can be combined or not with the aforementioned characteristic which states that the locking means exert a tension force upon each other.

15

According to a third important preferred form of embodiment, the characteristics of which may or may not be combined with the characteristics of the embodiments described above, the floor covering is characterized in that the lower lip which limits the lower side of the groove, extends beyond the upper lip; that the locking means are formed at least of a portion which inwardly slopes downward; and that this portion, at least partially, is located in the portion of the lower lip which extends beyond the upper lip. The advantages of these features will appear from the further description.

20

25

30

According to a preferred form of embodiment, the floor panels consist of elongated panels and the coupling parts described above are applied along the longitudinal sides of these panels.

35

According to a particular form of embodiment, coupling

parts are provided at the other two sides, too, either of another construction than described above or not.

5 In the most preferred form of embodiment, for the basic material use shall be made of the aforementioned product, which, as said, is ground and, by means of a binding agent, composed to a single compound. More particularly, for the core use shall be made of finely-ground wood which preferably is glued, more particularly, watertight  
10 glued. Still more particularly, for the core use shall be made of so-called HDF board (High Density Fibreboard) or MDF board (Medium Density Fibreboard).

The fact that the invention is applied to floor panels  
15 the basic material of which consists of the material described above, offers the advantage that with the processing of this material, very smooth surfaces are obtained whereby very precise couplings can be realized, which, in first instance, is important in the case of a  
20 snap-together connection and/or turning connection free from play. Also, very special forms of coupling parts can be manufactured in a very simple manner because the aforementioned kinds of material can be processed particularly easy.

25

The surfaces obtained with HDF and MDF also have the advantage that the floor panels mutually can fluently be shifted alongside each other in interlocked condition, even when engaged with a tensioning force.

30

The inventor also found out that the aforementioned materials, in particular HDF and MDF, show ideal features in order to realize a connection, such as mentioned above, as these materials show the right features in  
35 respect to elastic deformation in order to, on one hand, realize a snap-together effect, and, on the other hand,



receive expansion and shrinkage forces in an elastic manner, whereby it is avoided that the floor panels come unlocked or are damaged in an irreparable manner.

5 In the case that for the core use is made of a material based on synthetic material, to this end solid synthetic material can be used as well as a mixture of synthetic materials, eventually composed of recycled materials.

10 The floor covering preferably is formed by joining the floor panels into each other free of glue. Hereby, the connections are of such nature that the floor panels can be disassembled without being damaged, such that, for example, when moving, they can be taken along in order to  
15 be placed again. It is, however, clear that a glueing between tongue and groove is not excluded.

The invention, of course, also relates to floor panels which allow the realization of the aforementioned floor  
20 covering.

The invention also relates to a method for the manufacturing of the aforementioned floor panels which shows the advantage that the tongues and/or grooves,  
25 including the corresponding locking means, can be provided at the floor panels at high production speeds without problems. More particularly, it aims at a method which allows that the rather complicated forms of the tongue and the groove of the aforementioned floor panels  
30 can be realized completely by means of milling cutters, the diameter of which can be chosen independently of the form to be realized, such that the use of small milling cutters, for example finger cutters, with diameters smaller than the depth of the tongue or groove can be  
35 excluded.

To this aim, this method shows the characteristic that the tongue and/or groove is realized by means of a milling process with at least two subsequent milling cycles by means of milling cutters which are positioned in different angles in respect to the related floor panel. During each of the aforementioned milling cycles, preferably substantially the final form of one flank, either of the tongue or of the groove, is realized.

For the aforementioned two milling cycles, thus, milling cutters are used which extend outside the groove, respectively the tongue. More particularly the diameters of these milling cutters shall at least be 5 times and even better 20 times larger than the thickness of the floor panels.

The use of milling cutters showing the aforementioned diameters has as an advantage that the normal production speeds can be maintained which are also applied during milling of a classical straight tongue and groove. There is also the advantage obtained that the installation of such milling cutters induce only minor or no additional costs because such milling cutters can be placed directly upon a motor shaft and/or the usual machines can be used.

With the intention of better showing the characteristics according to the invention, in the following, as an example without any limitative character, several preferred forms of embodiment are described, with reference to the accompanying drawings, wherein:

figure 1 represents a floor panel of a floor covering according to the invention;

figure 2, on a larger scale, represents a cross-section according to line II-II in figure 1;

figures 3 and 4 represent how two floor panels with

coupling parts according to figure 2 match into each other;

figure 5, on a larger scale, represents a cross-section according to line V-V in figure 1;

5 figures 6 and 7 represent how two floor panels with coupling parts according to figure 5 match into each other;

10 figures 8 to 11 represent a number of variants of coupling parts of floor panels according to the invention;

figure 12 schematically represents how the floor parts can be provided with coupling parts;

figure 13 represents a cross-section according to line XIII-XIII in figure 12;

15 figures 14 to 21, on a larger scale and in cross-section, represent the penetration of the milling cutters which are indicated in figure 12 with arrows F14 to F21;

20 figure 22 represents a floor panel according to the invention;

figure 23, on a larger scale, represents the coupling of two floor panels of figure 22;

figures 24 and 25 represent two manners of coupling floor panels according to figure 22 to each other.

25

The invention relates to a floor covering which is composed of hard floor panels 1, for example, such as shown in figure 1.

30 These floor panels 1 can be of various shape, for example, rectangular or square, or of any other shape.

In the most preferred form of embodiment, they shall be manufactured in an elongated form, such as shown in  
35 figure 1, for example, with a length of 1 to 2 meters. The thickness, however, can also vary, but is preferably

0,5 to 1,5 cm, and more particularly 0,8 cm.

Each floor panel 1 is, at least at the edges of two opposite sides 2-3, provided with coupling parts 4-5 which allow that two adjacent floor panels 1 can be coupled to each other.

According to the invention, the coupling parts 4-5, as represented in the figures 2 to 4, are provided with integrated mechanical locking parts 6 which prevent the drifting apart of two coupled floor panels 1 into a direction D perpendicular to the respective sides 2-3 and parallel to the underside 7 of the coupled floor panels 1; the coupling parts 4-5 and the locking means 6 are realized in one piece with the core 8 of the floor panels 1; the coupling parts 4-5 have such a shape that two subsequent floor panels 1 can be engaged into each other exclusively by snapping-together and/or turning, whereby each subsequent floor panel 1 can be laterally inserted into the previous; and the coupling parts 4-5 preferably provide in an interlocking free from play according to all directions in the plane which is situated perpendicular to the aforementioned edges.

In the case of floor panels 1 with an elongated shape, as represented in figure 1, the respective coupling parts 4-5 are situated at the longitudinal sides 2-3.

The coupling parts 4-5 can be realized in various forms, although the basic forms thereof will always be formed by a tongue 9 and a groove 10.

In the form of embodiment of figures 2 to 4, the related floor panel 1 is provided with coupling parts 4-5 and locking means 6 which allow to mutually engage two floor panels 1 by means of a turning movement, without the

occurrence of any snap-together effect.

5 In the represented example, the locking means 9 consist of a first locking element 11, formed by a protrusion with a bent round shape at the lower side 12 of the tongue 9, and a second locking element 13, formed by a recess with a bent hollow shape in the lower wall 14 of the groove 10.

10 The locking elements 11-13 provide for that two floor panels 1 which are coupled to each other can not perform a lateral movement in the horizontal plane in respect to each other.

15 In order to obtain that two floor panels 1 can be inserted into each other by means of a turning movement, the curvatures preferably are circle-shaped. The bottom side 12 has a curvature with a radius  $R_1$ , the center of which coincides with the related upper edge 15 of the floor panel 1, whereas the lower wall 14 shows a curvature with a radius  $R_2$  which is equal to the radius  $R_1$ , but whereby its center coincides with the related upper edge 16. Radii  $R_1$  and  $R_2$  may also be applied which are larger or smaller than the distance to the upper edge 20 15, 16 respectively, and/or which differ from each other in size.

The upper side 17 of the tongue 9 and the upper wall 18 of the groove 10 are preferably flat and preferably are 30 situated in the horizontal plane.

The front sides 19 and 20 of the tongue 9 and the groove 10 of two interlocked floor panels 1 preferably do not fit closely against each other, such, that in between an 35 intermediate space 21 is created into which possible dust remainders or such can be pushed away by means of the

tongue 9.

The tongue 9 and the groove 10 preferably have shapes which are complementary to each other, such that the tongue 9 in the engaged condition of two floor panels 1 precisely sits against the upper wall 18 and the lower wall 14 of the groove 10, whereby a pressure P, executed onto the upper lip 22, is received not only by this lip 22, but by the complete structure, because this pressure can be transmitted through the tongue 9 and the lower lip 23.

It is, however, clear that a number of minor deviations to these complementary forms can occur which, anyhow, have no or almost no effect upon the receipt and transmission of pressure forces. For example, a chamfer 24 and a recess 25 can be provided, as represented in figures 2 to 4, as a result of which is obtained that the subsequent floor panels 1 can easily be pushed into each other, such that no possible ridges or such render the good insertion difficult.

As represented in the figures 5 to 7, the floor panels 1 according to the invention can also, along the sides 26-27 which are at a right angle to the sides 2-3, be provided with coupling parts 28-29 which have locking means 30, too. The coupling parts 28-29 are preferably also realized in the shape of a tongue 31 and a groove 32. Hereby, the locking means 30 do not have to be of the same nature as the locking means 6.

Preferably, at the sides 26-27 locking means are applied which allow for an engagement and interlocking by means of a translation movement T only, as represented in figures 6 and 7. To this aim, the locking means 30 consist of a snap-together connection with locking

elements 33 and 34 which grip behind each other.

As represented in figures 5 to 7, the locking element 33 preferably consists of a protrusion of the lower side 35 of the tongue 31 which can take place in a recess 36 in the lower wall 37 of the groove 32. The locking element 34 is formed by the upward directed part which limits the recess 36.

In this case, the locking elements 33-34 have contact planes 38-39 which are parallel to each other and preferably extend in an inclined manner, according to a direction which simplifies the snapping-together. The tangent line L which is determined by the contact planes 38-39, hereby forms an angle A with the underside 7 which is smaller than  $90^\circ$ .

The locking elements 33-34 preferably are provided with inclined portions 40 and 41 which, when engaging two floor panels 1, cooperate with each other in such a manner that the locking elements 33-34 can easily be pushed over each other until they grip behind each other by means of a snap-together effect.

The thickness  $W_1$  of the tongue 31 preferably is equal to the width  $W$  of the groove 32, such that the upper lip 42, when exerting a pressure  $P$ , is supported by the tongue 31 which, in its turn, then is supported by the lower lip 43.

Analogous to the chamfer 24 and recess 25, a recess 44 and a chamfer 45 are provided also at the edges 28-29.

It is noted that such a snap-together coupling can also be applied at the edges 2-3. Hereby, this can be a snap-together coupling analogous to these of figures 5 to 7,

but this can also be a snap-together coupling whereby other forms of coupling parts are applied, for example, such as represented in figures 8 and 9. Contrary to the locking elements 33-34 which consist of rather local protrusions, in the forms of embodiment of figures 8 and 9 use is made of locking elements 46-47 which, in comparison to the total width B of the coupling, extend over a rather large distance.

10 In this case, the locking elements 46-47 are also provided at the lower side 12 of the tongue 9 and the lower wall 14 of the groove 10.

15 According to figure 8, the locking elements 46-47 have contact surfaces 48-49 which are at an angle with the plane of the floor panel 1. Hereby, a coupling is obtained which is interlocked in a particularly fixed manner.

20 As represented in figure 9, the locking elements 46-47 possibly can be realized in such a manner that substantially only a linear contact is obtained, for example, because the contact surfaces directed towards each other are realized with different curvatures.

25 The surfaces, directed towards each other, of the locking elements 46-47 hereby consist of bent surfaces. The tangent line L forms an angle A which is smaller than  $90^\circ$ , and even better is smaller than  $70^\circ$ .

30 Hereby, the locking element 46 preferably has two portions with a different curvature, on one hand, a portion 50 with a strong curvature and, on the other hand, a portion 51 with a weak curvature. The portion 50 with the strong curvature provides for the formation of a firm coupling. The portion 51 with the weak curvature



allows that the coupling parts 4-5 can be brought into each other easily. The intermediate space S forms a chamber which offers space for dust and similar which, when engaging two floor panels 1, gets there eventually.

5

In the case of a snap-together connection, for example, a connection, such as represented in figures 7 to 9, preferably always the tongue 9-31 has a shape, thickening towards below, which can cooperate with a widened portion in the groove 10.

10

In figure 10, a variant is represented whereby at least at the height of the upper edges 15-16, a sealing material 52 is provided, as a result of which a watertight sealing can be guaranteed. This sealing material 52 may consist of a strip or covering which is provided previously at the floor panel 1, either at one or both upper edges 15-16.

15

In figure 11, a further variant is represented, whereby the locking means 6 are formed by an upward directed portion 53 at the tongue 9 which, as a result of a turning movement, is brought behind a downward-directed portion 54 at the upper wall 18. More particularly, this is obtained by realizing the upper side 17 and the upper wall 18 with a curvature R3, the center of which is situated at the edges 15-16, and realizing the lower side 12 and the lower wall 14 with a radius R4, the center of which is also situated at the upper edges 15 and 16, respectively. These radii R3-R4 can be chosen otherwise, too.

20

25

30

In general, according to the invention, the difference between, on one hand, the radius R1, R3 respectively, and, on the other hand, the radius R2, R4 respectively, preferably should not be larger than 2 mm.

35

It is also preferred that the center of these radii is situated inside the circle C1, C2 respectively, which extends with a radius R5 of 3 mm around the upper edge 15, 16 respectively, such as, for example, indicated in figure 2.

Finally is noted that, according to the invention, the lower lip 23-43, as represented in figures 2 to 7, can be realized longer than the upper lip 22-42. This has as an advantage that the coupling parts 4-5-28-29 can be realized in an easier manner by means of a milling cutter or such. Furthermore, this simplifies the engagement of two floor panels 1, because each subsequent floor panel 1 during installation can be placed upon the protruding lower lip 23-43, as a result of which the tongue 9-31 and the groove 10-32 automatically are positioned in front of each other.

The embodiments whereby the lower lip 23 is equal to or shorter than the upper lip 22, in their turn, offer the advantage that no protruding lip 23 remains at the extreme edge of the floor which might cause problems in the finishing.

In order to allow for a smooth assembly, in order to guarantee the necessary stability and firmness and in order to limit the quantity of material to be cut away, the difference E between the upper lip 22-42 and the lower lip 23-43, measured in the plane of the floor panel and perpendicular to the longitudinal direction of the groove 10, should preferably be kept smaller than one time the total thickness F of the floor panel 1. For stability's sake, normally this total thickness F shall never be less than 5 mm.

The small dimension of the difference E offers the

advantage that the lower lip must not be strengthened by a reinforcement strip or the like.

5 According to a particular form of embodiment, the central line M1 through the tongue 9 and the groove 10 is situated lower than the center M2 of the floor panel 1, such, that the upper lip 22-42 is thicker than the lower lip 23-43. In first instance, this is essential in this kind of connections, because then it is the lower lip 23-10 43 which bends, such that the upper side of the floor panel 1 is kept free of possible deformations.

As explained in the introduction, for the core 8 a material is chosen from the following series:

- 15 -a ground product which, by means of a binding agent or by means of melting together, is composed to a single compound;
- a product based on synthetic material;
- 20 -chip board with fine chips.

The invention shows its usefulness, in first instance, preferably with laminated flooring, due to the reasons explained in the introduction.

25 As represented in the examples of the figures 2 to 11, such laminated flooring preferably consists of a core 8 made of MDF board, HDF board or similar, whereby at least at the upper side of this core 8 one or more layers of material are provided.

30 More particularly, it is preferred that the laminated flooring is provided with a decorative layer 55 and a protective top layer 56. The decorative layer 55 is a layer, impregnated with resin, for example, made of paper, which can be imprinted with a variety of patterns, 35 such as a wood pattern, a pattern in the form of stone,

cork, or similar or even with a fancy pattern. The protective top layer 56 preferably also consists of a layer saturated with resin, for example, melamine resin, made of a transparent material.

5

It is clear that still other layers can be applied, such as an intermediate layer 57 upon which the decorative layer 55 is provided.

10 Preferably, also a backing layer 58 shall be applied at the underside 7, forming a counterbalancing element for the top layers and, thus, guaranteeing the stability of the form of the floor panel 1. This backing layer 58 may consist of a material, for example paper, impregnated  
15 with a resin, for example, a melamine resin.

As represented schematically in figure 12, the tongue 9 and the groove 10, and preferably also the tongue 31 and the groove 32 are applied by means of a milling process.

20 In the case that a profile has to be applied on all four sides, the floor panels 1 preferably shall be displaced by means of two perpendicular movements V1 and V2, whereby during the first movement profiles at two opposite edges are provided, in this case the  
25 longitudinal edges, by means of milling devices 59-60, whereas during the second movement profiles are provided at the other edges, in this case the small edges, by means of milling devices 61-62. During these processing, the floor panels 1 preferably are put with their  
30 decorative layer directed downward.

According to an important characteristic of the invention, each respective tongue 9-31 and groove 10-32 are realized by means of a milling process with at least  
35 two subsequent milling cycles by means of milling cutters which are positioned at different angles in reference to

the related floor panel 1.

This is illustrated in figures 13, 14 and 15, wherein it is represented how a groove 10 is realized by means of two milling cycles by means of two milling cutters 63 and 64. Figures 16 and 17 represent how the tongue 9 is realized by means of milling cutters 65 and 66.

The figures 18-19 and 20-21 represent similar views showing how the groove 32 and the tongue 31 are realized by means of milling cutters 67-68 and 69-70, positioned at an angle.

During each of the aforementioned milling cycles, each time substantially the final shape of one flank is realized. For example, the milling cutter 63 of figure 14 determines the final shape of the lower flank 71 of the groove 10, whereas the milling cutter 64 determines the final shape of the upper flank 72.

As mentioned in the introduction, preferably milling cutters 63 to 72 shall be applied, having diameters  $G$  which are at least 5 times, and even better at least 20 times larger than the thickness  $F$  of the floor panels 1.

Apart of the mentioned milling cutters, preferably still other milling cutters are applied, for example, in order to remove a part of the material to be removed already during a first premachining cycle.

In the figures 22 to 25, a particularly preferred form of embodiment of a floor panel 1 according to the invention is represented. Hereby, the parts which are taken over from the foregoing forms of embodiment are indicated with corresponding references.

An important characteristic herein consists in that the coupling parts 4-5 are provided with locking means 6 which, in engaged condition, exert a tension force upon each other, as a result of which the engaged floor portions 1 are forced towards each other. As represented, this is realized preferably by providing the coupling parts with an elastically bendable portion, in this case the lip 43, which, in engaged condition, is at least partially bent and in this way creates a tension force which provides for that the engaged floor panels 1 are forced towards each other. The hereby resulting bending  $V$ , as well as the tension force  $K$  resulting herefrom, are indicated in the enlargement of figure 23.

In order to obtain that the tension force  $K$  results in pressing together the engaged floor panels 1, the bendable portion, in this case the lip 43, preferably is provided, as represented, with an inwardly inclined contact surface 73 which preferably can cooperate with a corresponding contact surface 74. These contact surfaces 73-74 are similar to the aforementioned contact surfaces 39-38 and also similar to the inclined portions of the lower lip of figures 2 to 4.

In the figures 2 and 5, the portions form complementary matching shapes; it is, however, clear that, by a modification, also a tension effect similar as in figure 23 can be realized.

Due to, on one hand, the contact under the angle  $A$ , and, on the other hand, the fact that a tension force  $K$  is created, a force component  $K_1$  is effected, as a result of which the floor panels 1 are drawn against each other.

Preferably, the angle  $A$  of the contact surfaces 73-74 in respect to the horizontal plane is situated between 30

and 70 degrees. In first instance in the case that use is made of the embodiment whereby a tension force  $K$  is realized, an angle  $A$  of 30 to 70 degrees is ideal in order, on one hand, to effect an optimum pressing-together of the floor panels 1 and, on the other hand, to obtain that the floor panels 1 can easily be engaged, respectively disassembled.

Although the pressing force  $K_1$  preferably is delivered by the aforementioned lip 43, the invention does not exclude other forms of embodiment whereby this force is delivered by other bendable portions.

It is noted that the bending  $V$  is relatively small, for example, several hundredths up to several tenths of a millimeter, and does not have an influence upon the placement of the floor covering. Furthermore is noted that such floor covering generally is placed upon an underlayer which is elastically compressible, as a result of which the bending  $V$  of the lip 43 exclusively results in the fact that the underlayer locally is compressed somewhat more.

Due to the fact that the lip 43 is bent apart and that it remains somewhat bent apart in engaged position, also the advantage is effected that, when exerting a pressure upon the floor covering, for example, when placing an object thereupon, the pressing-together force is enhanced and, thus, the development of gaps is counteracted even more.

It is noted that the inventor has found that, contrary to all expectations, an ideal tension force can be realized by manufacturing the coupling parts 4-5, including the locking elements 33-34, and preferably the complete core 8, of HDF board or MDF board, although these materials only allow a minor elastic deformation.

HDF and MDF also offer the advantage that smooth surfaces are obtained, as a result of which the locking elements can be moved easily over each other.

5 According to a variant of the invention, the tension force can also be delivered by means of an elastic compression of the material of the coupling parts, to which end these coupling parts, and preferably the complete core 8, then have to be manufactured in an  
10 elastically compressible material.

A further particular characteristic of the embodiment of figures 22 to 25 consists in that the floor panels 1 can be engaged by means of a turning movement, as represented  
15 in figure 24, as well as by means of shifting them towards each other, as represented in figure 25, preferably in such a manner that, during the engagement by means of the turning movement, a maximum bending  $V_m$  results in the coupling parts, more particularly in the  
20 lip 43, which bending  $V_m$  is less pronounced, if not non-existent, as in the figures 2 to 4, in comparison to the bending  $V_m$  which results when the floor panels 1 are engaged by means of shifting them towards each other.

25 The advantage of this consists in that the floor panels 1 can be engaged easily by means of a turning movement, without necessitating a tool therefore, whereas it still remains possible to engage the floor panels also by means of shifting them. This latter is useful, in first  
30 instance, when the last panel has to be placed partially under a door frame or similar. In this case, the floor panel 1 can be pushed under the door frame with the side which does not have to be engaged and subsequently, possibly by means of tools, can be snapped into the  
35 adjacent floor panel 1.



It is noted that the shapes of the coupling parts 4-5 shown in figures 22 to 25 can also be used for the coupling parts 28-29 of the short sides.

5 According to the invention, in the case that the four sides 2-3-26-27 are provided with coupling parts 4-5-28-29, these coupling parts can be realized in such a manner that in one direction a firmer engagement than in the other direction is effected. In the case of elongated  
10 floor panels 1, for example, such as represented in figure 1, the locking at the small sides 26-27 preferably shall be more pronounced than at the longitudinal sides 2-3. The length of the coupling at the small sides, namely, is smaller and, in principle, less firm. This is  
15 compensated by providing in a more pronounced locking.

This difference in engagement can be obtained by realizing the contact surfaces 73-74 under different angles.

20 Preferably, the aforementioned protrusion, more particularly the locking element 33, is bordered by at least two portions 75-76, respectively a portion 75 with a strong inclination which provides for the locking, and  
25 a portion 76 with a weaker inclination which renders the engagement of the coupling parts easier. In the embodiment of figures 22 to 25, these portions 75-76 are formed by straight planes, but, as already described in reference to figure 9, use can also be made of curved  
30 portions 50-51. In figure 5, these are the contact surface 38 and the inclined portion 40.

In the preferred form of embodiment, the floor panels 1 according to the invention comprise coupling parts 4-5  
35 and/or 28-29 showing one of the following or the combination of two or more of the following features:

- 5 - a curvature 77 at the lower side of the tongue 9 and/or a curvature 78 at the lip 43 which form a guidance when turning two floor panels 1 into each other, with the advantage that the floor panels 1 can be engaged into each other easily during installing;
- 10 - roundings 79-80 at the edges of the locking elements 33-34, with the advantages that the locking elements can easily shift over each other during the engagement, respectively disassembly of the floor panels 1 and that the locking elements are not damaged, for example, crumble away at their edges, even if the floor panels are engaged, respectively disassembled, repeatedly;
- 15 - dust chambers 81, or spaces 21 as in figure 4, between all sides, directed laterally towards each other, of the engaged floor panels 1, with the advantage that inclusions which get between the floor panels 1 during the engagement do not exert a disadvantageous influence upon the good engagement;
- 20 - a shaping of the tongue 9 which is such, for example, by the presence of a chamfer 82, that the upper side of the tongue 9 already with the first contact becomes situated under the lower side of the upper lip 42 when the floor panels 1 are pushed towards each other at the same level, as indicated in figure 25, with the advantage that the front extremity of the tongue 9 does not press against the front side of the upper lip 42 when the floor panels are pushed towards each other at the same level;
- 25 - a ramp surface 83, hereinbefore also called inclined portion 41, formed at the free extremity of the lower lip 43, with the advantage that the locking elements 33-34 shift smoothly over each other and that the lower lip 43 is bent uniformly;
- 30 - in the engagement direction only one important contact point which is formed by a section 84 at the
- 35

location of the top side of the floor panels 1, with the advantage that the aforementioned tension force is optimally transferred to the upper side of the floor panels 1 and that the development of openings between the floor panels 1 is counteracted;

5 - contact surfaces 85-86, more particularly abutment surfaces, formed by the upper side of the tongue 9 and the upper side of the groove 10 which, over the largest portion of their length, run parallel to the plane which is defined by the floor panels 1, as well as contact surfaces cooperating with each other, formed by curvatures 77-78, with the advantage that no mutual displacement in height between two engaged floor panels 1 is possible, even if the insertion depth of the tongue 9 into the groove 10 should vary due to which causes whatsoever, in other words, that no height differences may occur between the adjacent floor panels.

10  
15  
20 In the form of embodiment of figures 22 to 25, all these characteristics are combined; it is, however, clear that, as becomes evident from figures 2 to 11, these features can also be present separately or in a limited combination.

25  
30  
35 As becomes evident from figures 5 to 7 and 22 to 25, an important characteristic of the preferred form of embodiment of the invention consists in that the locking means 6, in other words, the portion providing for the snap-together and engagement effect, are situated in that portion of the lower lip 23-43 which extends beyond the upper lip 22-42, more particularly, that the lowermost point 87 of the locking part 33 is situated under the top layer of the floor panel 1. For clarity's sake, this top layer is indicated in the figures 22 to 25 only as a single layer.

It is noted that the combination of features, that the lower lip 23-43 extends further than the upper lip 22-42, that the locking means 6 are formed at least by means of a portion which inwardly slopes downward, and that this portion, at least partially, is located in the portion of the lower lip 23-43 which extends beyond the upper lip 22-42, is particularly advantageous, among others, in comparison with the couplings for floor panels described in the documents WO 94/01628, WO 94/26999, WO 96/27719 and WO 96/27721. The sloping portion offers the advantage that the floor panels 1 can be disassembled again. The fact that this sloping portion is situated in the further extending portion of the lower lip 23-43 additionally to this offers the advantage that no deformations can occur during coupling which manifest themselves up to the top layer.

According to a preferred characteristic of the invention, the aforementioned portion, i.e. the contact surface 39 or 73, preferably extends in such a manner that the distance up to the upper edge 16 diminishes from below in upward direction, in other words, such that, as represented in figure 22, the distance X2 is smaller than the distance X1. This is also the case in figure 7.

Still preferably, this portion only starts at a clear distance E1 from the upper lip 42.

It is obvious that the coupling parts 22 to 25 can also be realized by means of said milling process.

According to a particular characteristic of the invention, the floor panels 1 are treated at their sides 2-3 and/or 26-27 with a surface densifying agent, more particularly a surface hardening agent, which preferably is chosen from the following series of products:

impregnation agents, pore-sealing agents, lacquers, resins, oils, paraffines and similar.

5 In figure 22, such impregnation 88 is represented schematically. This treatment can be performed over the complete surface of the sides 2-3 and/or 26-27 or only over well-defined portions hereof, for example, exclusively the surfaces of the tongue 9 and the groove 10.

10 The treatment with a surface densifying agent offers, in combination with the snap-together effect, the advantage that in various aspects better coupling features are obtained. As a result of this, the coupling parts 4-5  
15 and/or 28-29 better keep their shape and strength, even if the floor panels 1 are engaged and disassembled repeatedly. Especially in the case that for the core 8 use is made of HDF, MDF or similiar, by means of this treatment such a better quality of surface condition is  
20 obtained, that no abrasion of material occurs during engaging, respectively during disassembling.

25 This treatment also offers the advantage that, at least in the case of a surface hardening, the aforementioned elastic tensioning effect is enhanced.

30 The present invention is in no way limited to the forms of embodiment described by way of example and represented in the figures, however, can such floor covering and the pertaining floor panels 1 be realized in various forms and dimensions without leaving the scope of the invention.

35 For example, the various characteristics which are described by means of the represented forms of embodiment, may be combined with each other or not.

Furthermore, all embodiments of coupling elements described before can be applied at the longer side as well as at the shorter side.

Claims.  

---

- 1.- Floor covering, consisting of hard floor panels (1) which, at least at the edges of two opposite sides (2-3, 26-27), are provided with coupling parts (4-5, 28-29), cooperating which each other, substantially in the form of a tongue (9-31) and a groove (10-32), characterized in that the coupling parts (4-5, 28-29) are provided with integrated mechanical locking means (6) which prevent the drifting apart of two coupled floor panels into a direction (R) perpendicular to the related edges (2-3, 26-27) and parallel to the underside (7) of the coupled floor panels (1).
- 2.- Floor covering according to claim 1, characterized in that the coupling parts (4-5, 28-29) are provided with means, which are formed more particularly by the aforementioned locking means (6), which, in the engaged condition of two or more of such floor panels (1) exert a tension force upon each other which forces the floor panels (1) towards each other.
- 3.- Floor covering according to claim 2, characterized in that at least one of the coupling parts (5) has an elastically bendable portion which, in the engaged condition, is at least partially bent and in this manner provides the aforementioned tension force.
- 4.- Floor covering according to claim 3, characterized in that the elastically bendable portion consists of a lip, preferably the lip (43) limiting the lower side of the aforementioned groove (10).
- 5.- Floor covering according to claim 3 or 4, characterized in that the bendable portion is provided

with a contact surface (39-73) which inwardly slopes downward.

5 6.- Floor covering according to any of the foregoing claims, characterized in that the coupling parts (4-5, 28-29) and the locking means (6) are realized in one piece with the core (8) of the floor panels (1).

10 7.- Floor covering according to any of the foregoing claims, characterized in that the floor covering further shows the following combination of characteristics: that the coupling parts (4-5, 28-29) and locking means (6) are realized in one piece with the core (8) of the floor panels (1); that the coupling parts (4-5, 28-29) have  
15 such a shape that two subsequent floor panels (1) can be engaged into each other exclusively by snapping together and/or turning, whereby each subsequent floor panel (1) can be inserted laterally into the previous; that the coupling parts (4-5, 28-29) provide in an interlocking,  
20 free from play, according to all directions in the plane which is situated perpendicular to the aforementioned edges; that the possible difference (E) between the upper and lower lip of the lips (22-23, 42-43) which border the aforementioned groove (10, 32), measured in the plane of  
25 the floor panel (1) and perpendicular to the longitudinal direction of the groove (10, 32), is smaller than one time the total thickness (F) of the floor panel (1); that the total thickness (F) of each related floor panel (1) is larger than or equal to 5 mm; and that the basic  
30 material of the floor panels (1), of which the aforementioned core (8) and the locking means (6) are formed, consists of a ground product which, by means of a binding agent or by means of melting together, is composed to a single compound, and/or of a product on the  
35 basis of synthetic material and/or of a chip board with fine chips.



8.- Floor covering according to any of the foregoing claims, characterized in that the basic material of the floor panels (1), in other words, the material of the core (8), consists of HDF board or MDF board, whereby the coupling parts (4-5-28-29) and the locking means (6) are formed out of this board.

9.- Floor covering according to any of the foregoing claims, characterized in that the floor panels (1) consist of elongated panels and that, at least at their longitudinal sides (2-3), they are provided with the aforementioned coupling parts (4-5).

10.- Floor covering according to any of the claims 1 to 8, characterized in that the floor panels (1) are rectangular or square and that, on all four sides (2-3-26-27), more particularly two by two, they are provided with the aforementioned coupling parts (4-5-28-29).

11.- Floor covering according to any of the foregoing claims, characterized in that the coupling parts (4-5 and/or 28-29) of at least two opposite sides (2-3, 26-27) are realized in such a manner that the floor panels (1) can be engaged by means of shifting them towards each other as well as by means of a turning movement, whereby, during the engagement by means of the turning movement, a bending occurs in the coupling parts (4-5 and/or 28-29), which bending is less pronounced, if not non-existent, in comparison to the bending which occurs when the floor panels (1) are engaged by means of shifting them towards each other.

12.- Floor covering according to any of the foregoing claims, characterized in that the locking means (6) substantially consist of a locking element (11-33-46) in the form of a protrusion, provided at the lower side (12)

of the tongue (9, 31), and a locking element (13-34-47), formed in the lip which borders the lower side of the groove (10), more particularly in the lower wall (14) of the groove (10-32), in the form of a recess (36) and/or upward directed part which is limited by this recess (36).

13.- Floor covering according to claim 12, characterized in that the lower side of the aforementioned protrusion is bordered by at least two portions (50-51, 75-76), respectively a portion (50-75) with a strong inclination providing for the locking effect, and a portion (51-76) with a weaker inclination which renders the engagement of the coupling parts (4-5) easier.

14.- Floor covering according to any of the foregoing claims, characterized that the coupling parts (4-5, 28-29) are provided with locking elements (33-34-46-47) allowing a snap-together connection.

15.- Floor covering according to claim 4 or 14, characterized in that the locking means (6) are provided with locking elements (33-34-46-47) which are realized in such a manner that the tangent line (L) which is defined by the contact surfaces, forms an angle (A) with the underside (7) of the floor panels which is 30 to 70 degrees.

16.- Floor covering according to any of the foregoing claims, characterized in that the coupling parts (4-5-28-29) are realized in the shape of a tongue (9-31) and a groove (10-32) and that the lip (23-43) bordering the lower side of the groove (11-32) extends beyond the lip (22-42) bordering the upper side of the groove (10-32).

17.- Floor covering according to claim 16, characterized

in that the locking means (6), amongst others, are formed by locking elements (34) which are located in the portion of the lower lip (23-43) which extends beyond the upper lip (22-42), more particularly that the lowermost point (87) of engagement of the locking elements (34) is located underneath the top layer of the floor panel (1) which carries the related tongue (9).

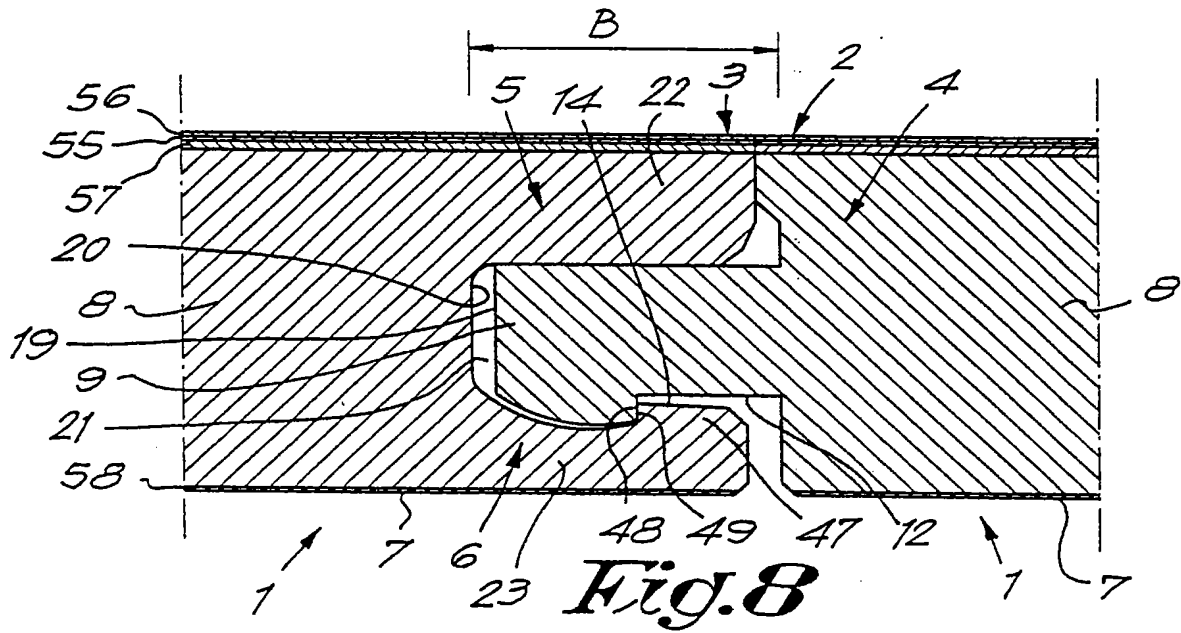
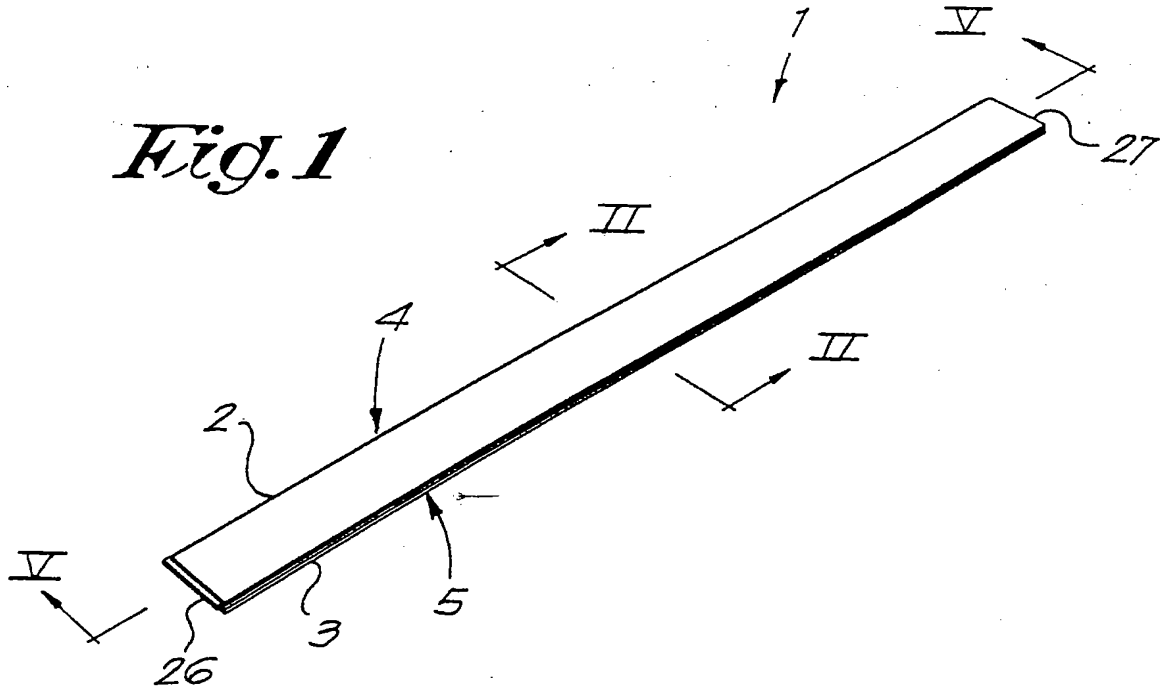
18.- Floor covering according to claim 16 or 17, characterized in that the coupling parts (4-5) show one of the following or the combination of two or more of the following features:

- a curvature (77) at the lower side of the tongue (9) and/or a curvature (70) at the lip (43) which form a guidance when turning two floor panels (1) into each other;
- roundings (79-80) at the edges of the locking elements (33-34);
- dust chambers or similar (21-44-81) between all sides of the engaged floor panels (1) which are directed laterally towards each other;
- a shaping of the tongue (9) which is such that the upper side of the tongue (9) already with the first contact becomes situated under the lower side of the upper lip (42) when the floor panels (1) are shifted towards each other at the same level;
- a ramp surface (41-83), formed at the free extremity of the lower lip (43);
- in the engagement direction only one substantial contact point which is formed by a section (84) at the location of the top side of the floor panels (1);
- contact surfaces (85-86), more particularly abutment surfaces, formed by the upper side of the tongue (9) and the upper side of the groove (10) which, over the largest portion of their length, run parallel to the plane which is defined by the floor panels (1).

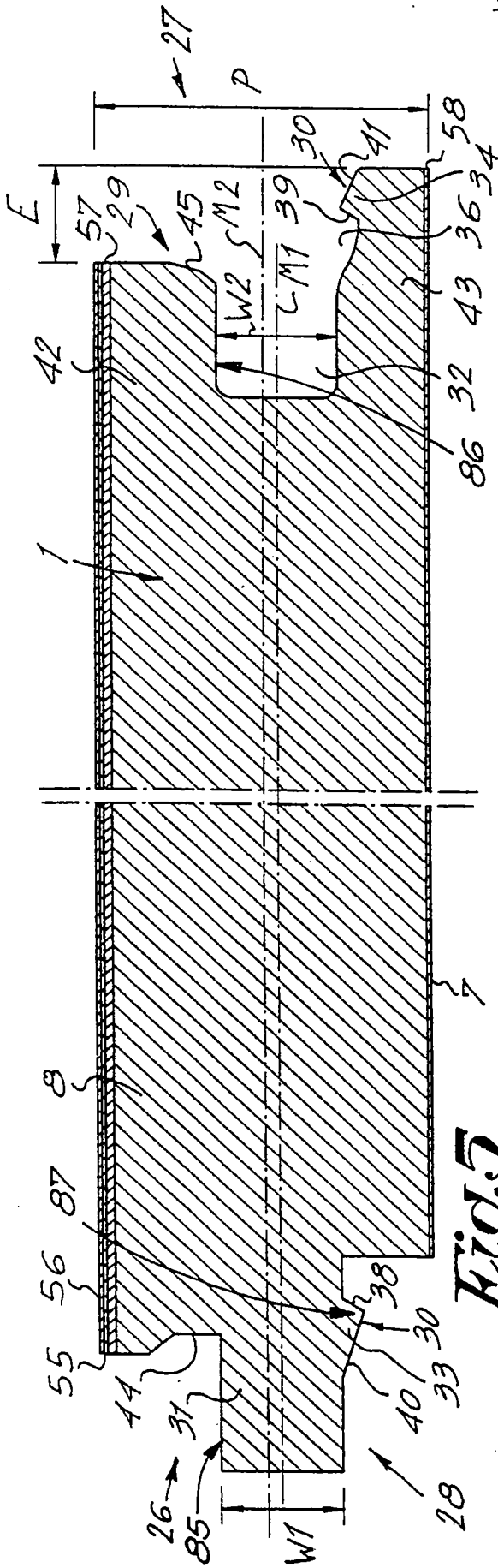
- 19.- Floor covering according to any of the foregoing claims, characterized in that the lower lip (23-43) which limits the lower side of the groove (10), extends beyond the upper lip (22-42); that the locking means (6) are formed at least of a portion which inwardly slopes downward; and that this portion, at least partially, is located in the portion of the lower lip (23-43) which extends beyond the upper lip (22-42).
- 20.- Floor covering according to claim 19, characterized in that the aforementioned portion (39-73) extends in such a manner that the distance (X1-X2) up to the upper edge (16) of the floor panel (1) diminishes from below in upward direction.
- 21.- Floor covering according to any of the foregoing claims, characterized in that the floor panels (1) are realized as laminated flooring, whereby on the core (8) one or more layers, among which a decorative layer (55), are provided and whereby a backing layer (58) is provided at the underside (7).
- 22.- Floor covering according to any of the foregoing claims, characterized in that the coupling parts at their surface, in other words, the edges of the floor panels (1), are treated with a surface densifying agent, more particularly, a surface hardening agent.
- 23.- Floor covering according to any of the foregoing claims, characterized in that the floor panels (1) are connected free of glue, such that they can be disassembled and be re-used.
- 24.- Floor panel for realizing a floor covering according to any of the claims 1 to 23.

- 25.- Method for manufacturing of floor panels, as described in any of the previous claims, characterized in that the tongue (9-31) and/or groove (10-32) is realized by means of a milling process with at least two subsequent milling cycles by means of milling cutters (63-64-65-66-67-68-69-70) which are positioned in different angles in respect to the related floor panel (1).
- 26.- Method according to claim 25, characterized in that during each of the aforementioned milling cycles each time substantially the final shape of one flank (71-72), either of the tongue or of the groove, is realized.
- 27.- Method according to claim 25 or 26, characterized in that for the aforementioned two milling cycles milling cutters (63-64-65-66-67-68-69-70) are applied which extend outside the groove (10-32), respectively the tongue (9-31), and more particularly show diameters (G) which are at least 5 times larger than the thickness (F) of the floor panels (1), and preferably even at least 20 times larger than the thickness (F) of the floor panels (1).
- 28.- Method according to any of the claims 25 to 27, characterized in that at all four sides of the floor panel (1) a profile is provided and that the floor panels (1) are displaced according to two perpendicular movements (V1-V2), whereby during one of the movements profiles at two opposite edges are provided, whereas during the other movement profiles are provided at the small edges.

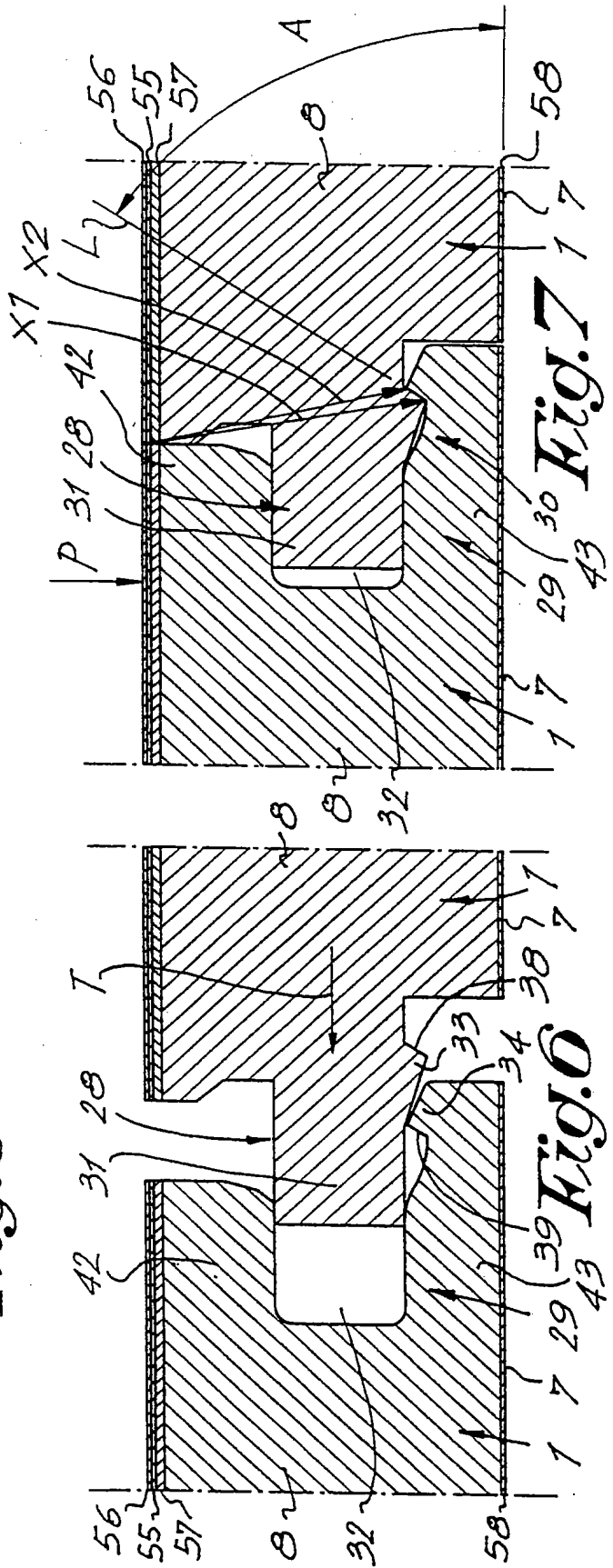
*Fig. 1*







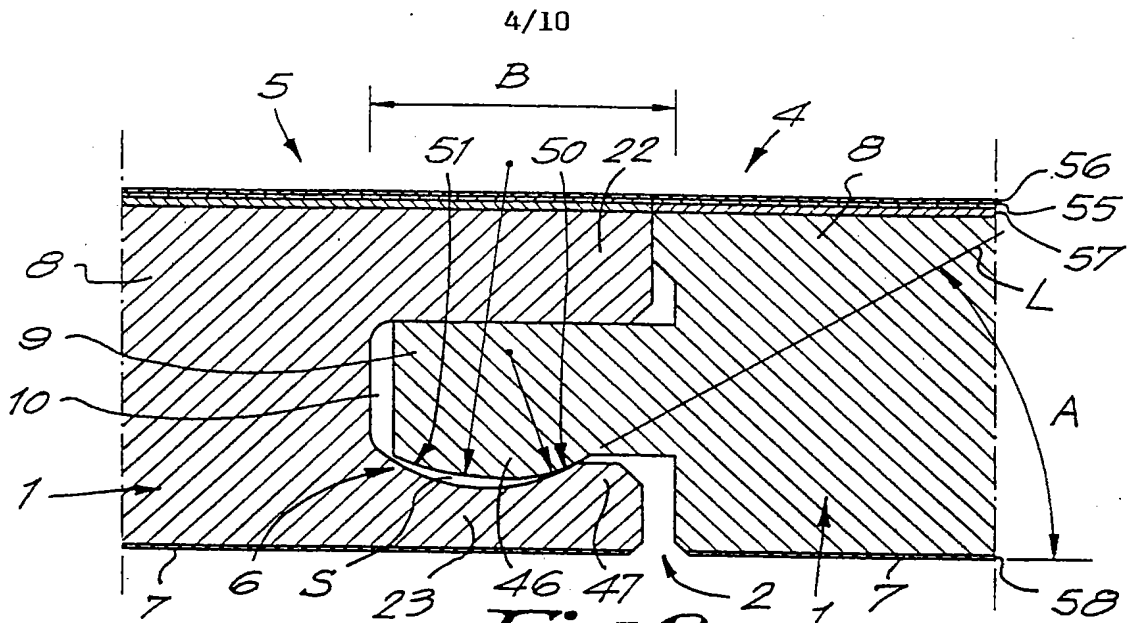
**Fig. 5**



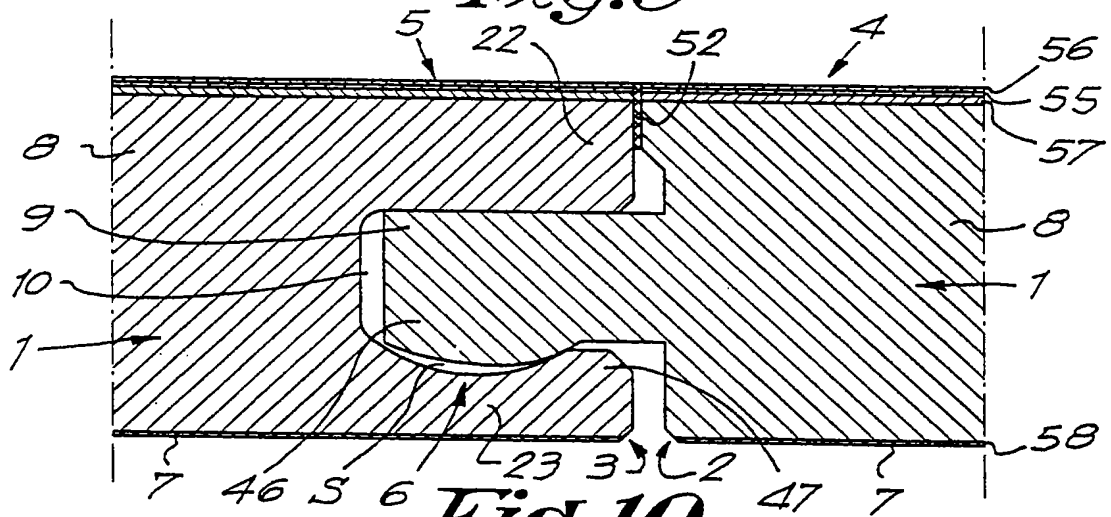
**Fig. 6**

**Fig. 7**

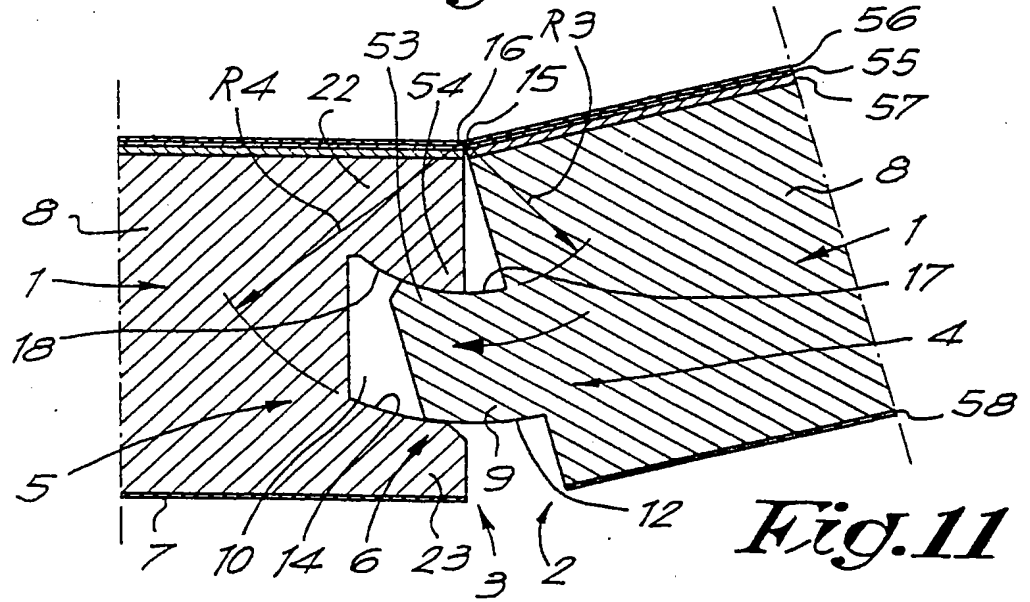




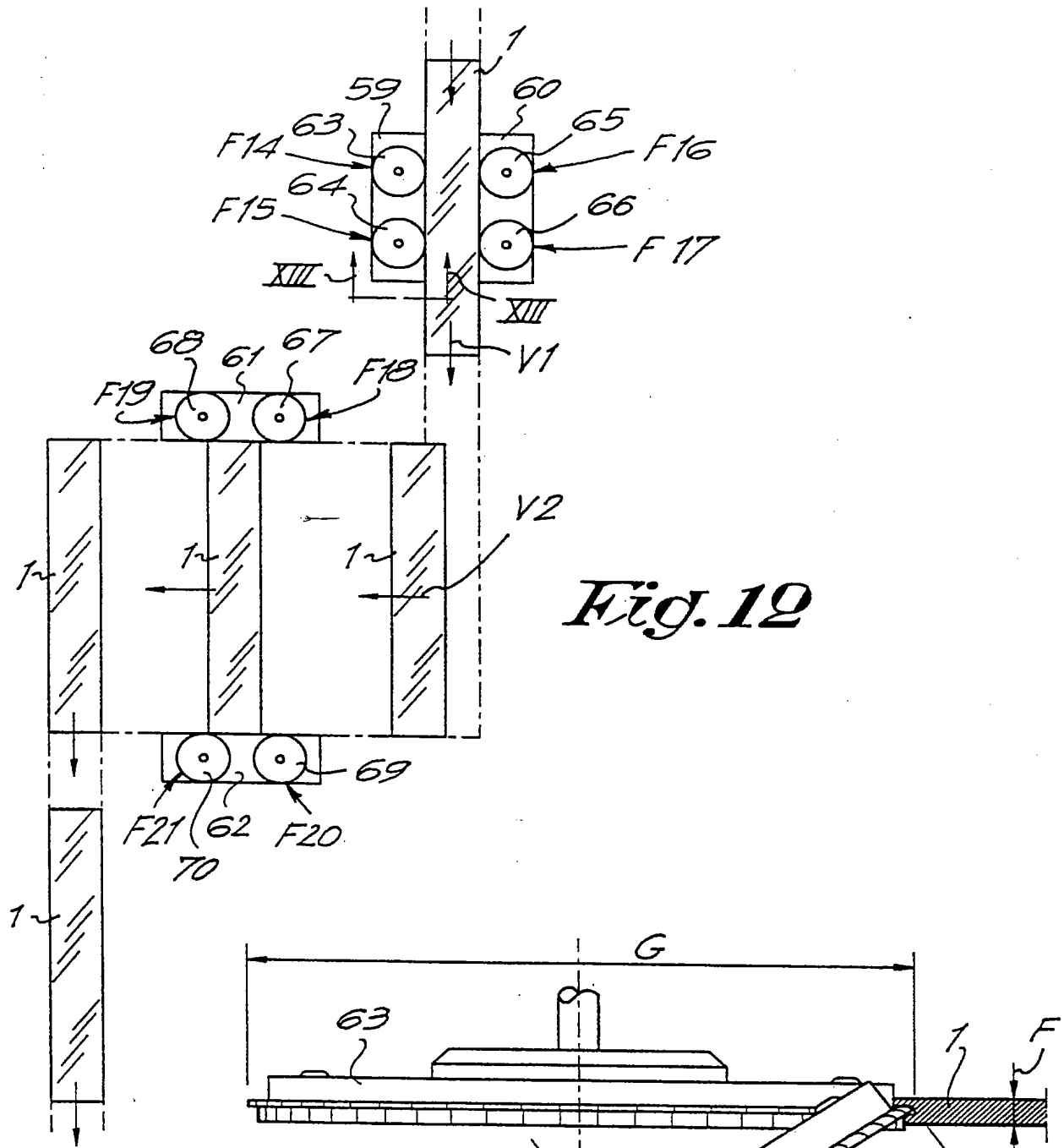
**Fig. 9**



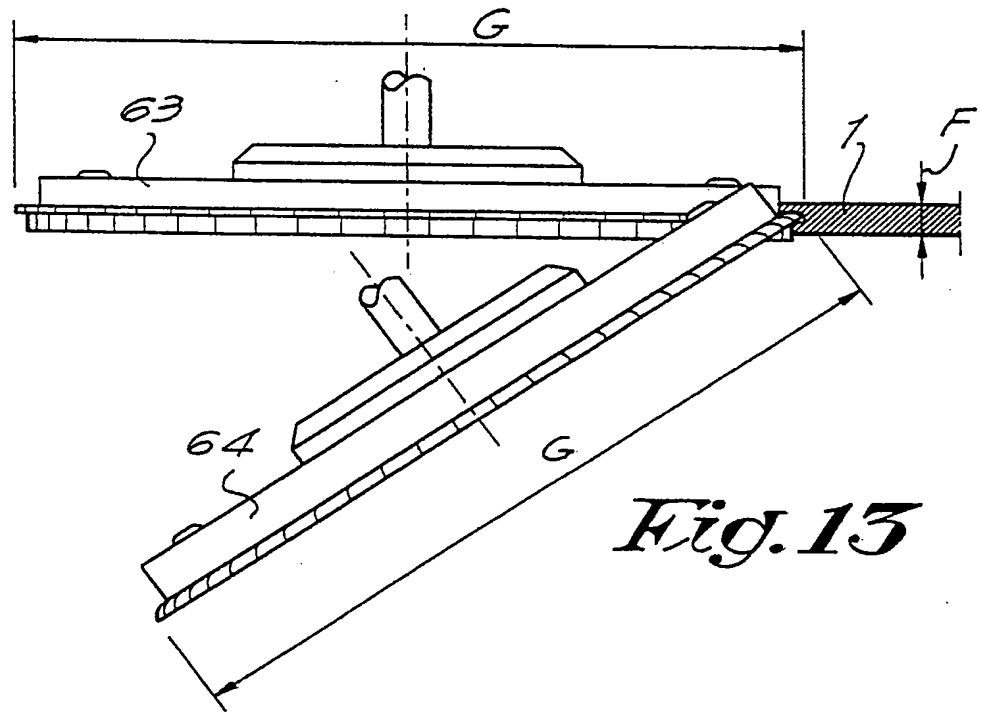
**Fig. 10**



**Fig. 11**

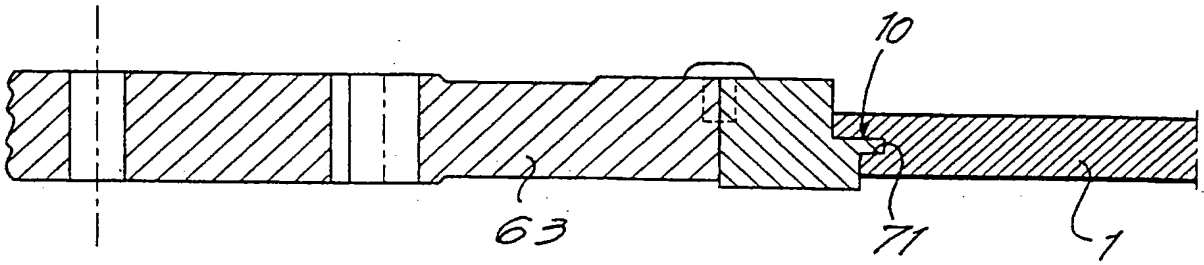


*Fig. 12*

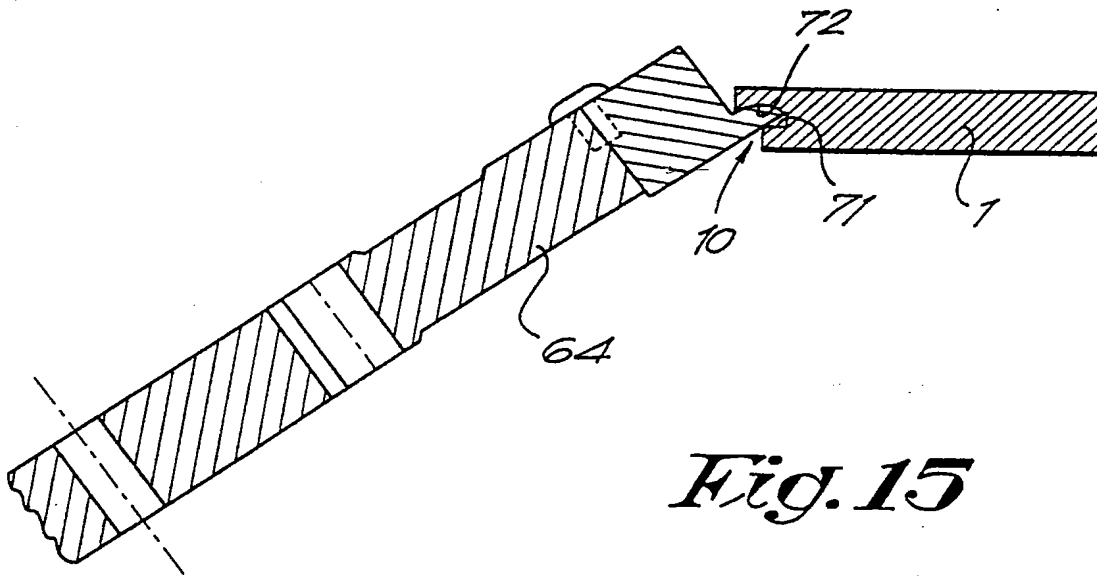


*Fig. 13*

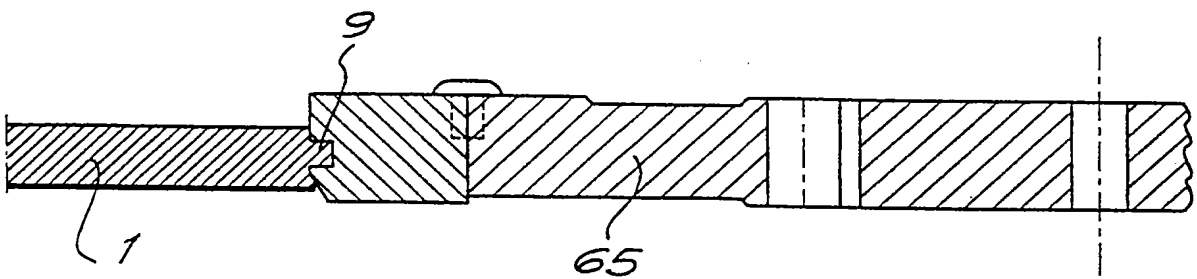
6/10



*Fig. 14*

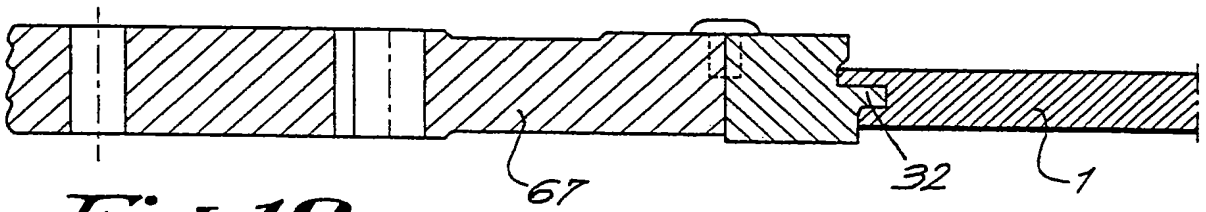
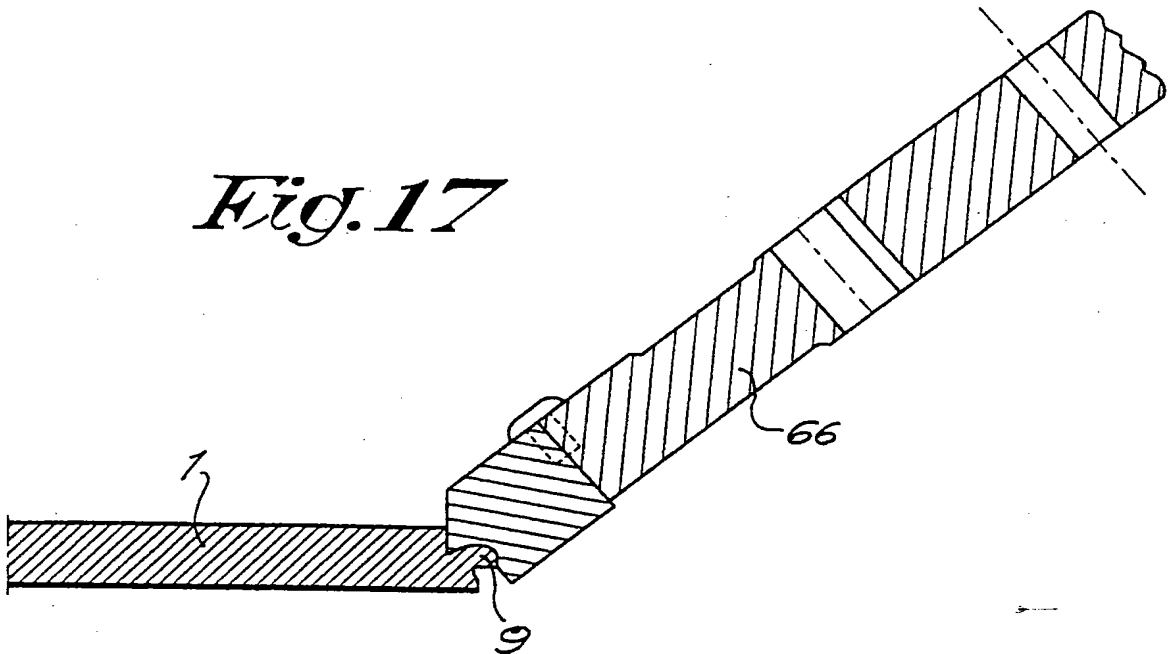


*Fig. 15*

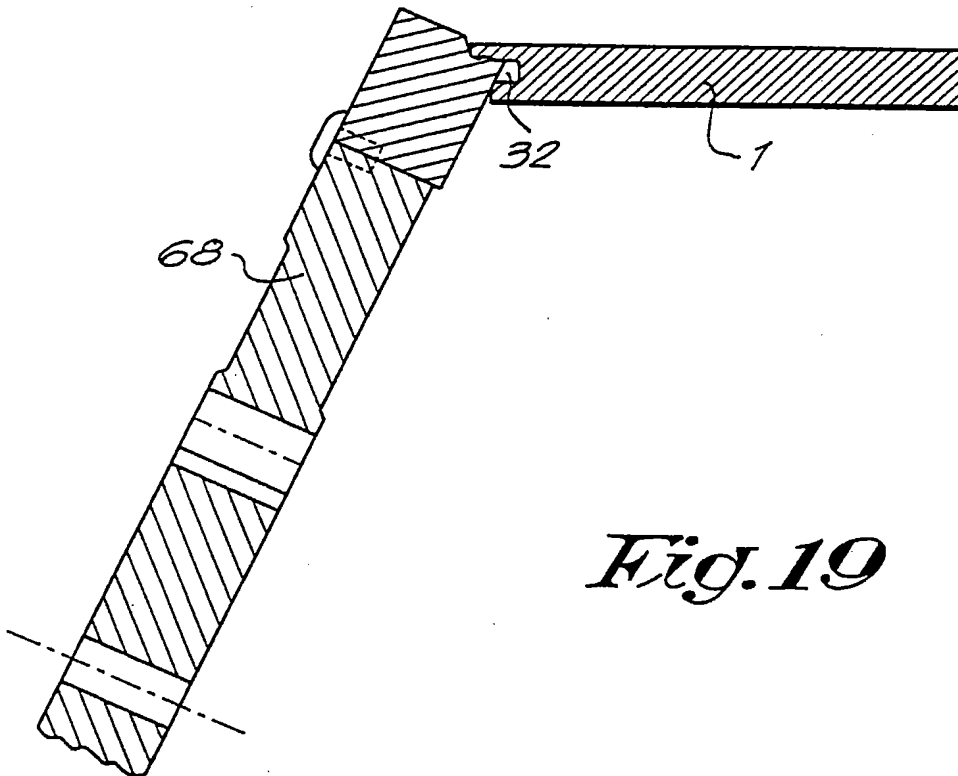


*Fig. 16*

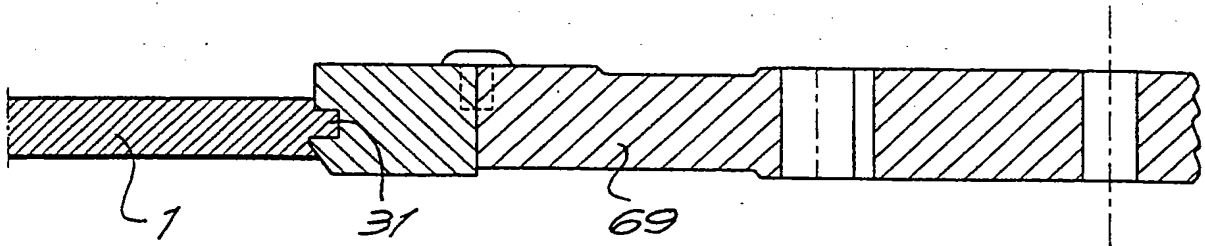
*Fig. 17*



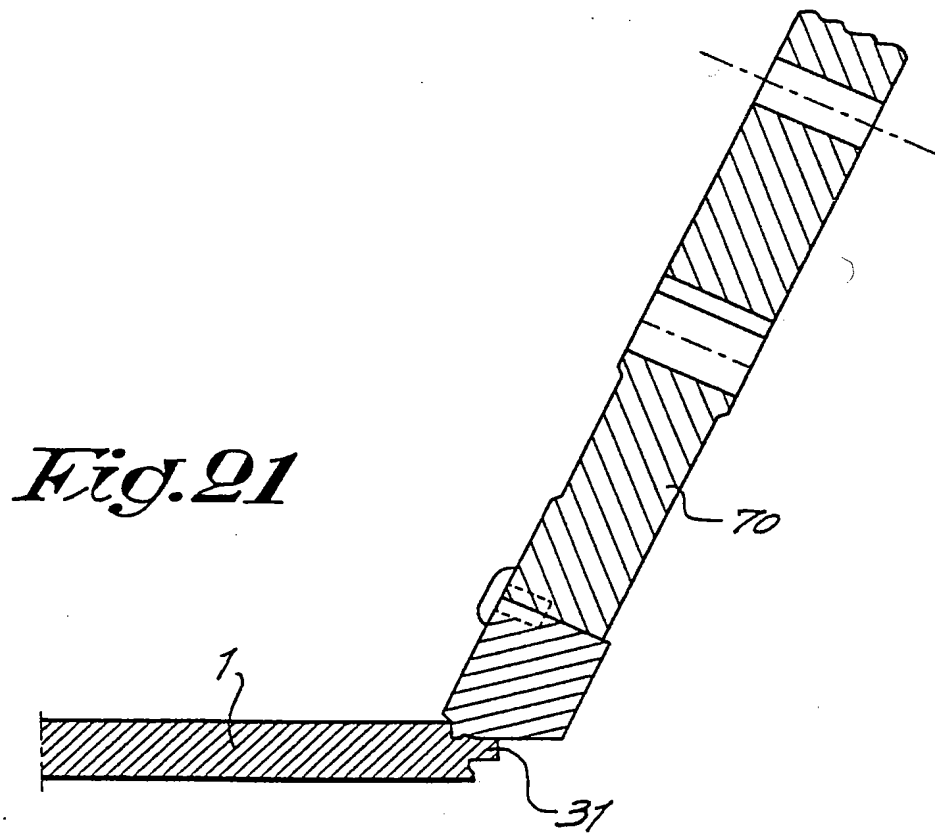
*Fig. 18*



*Fig. 19*



*Fig. 20*



*Fig. 21*

Fig. 22

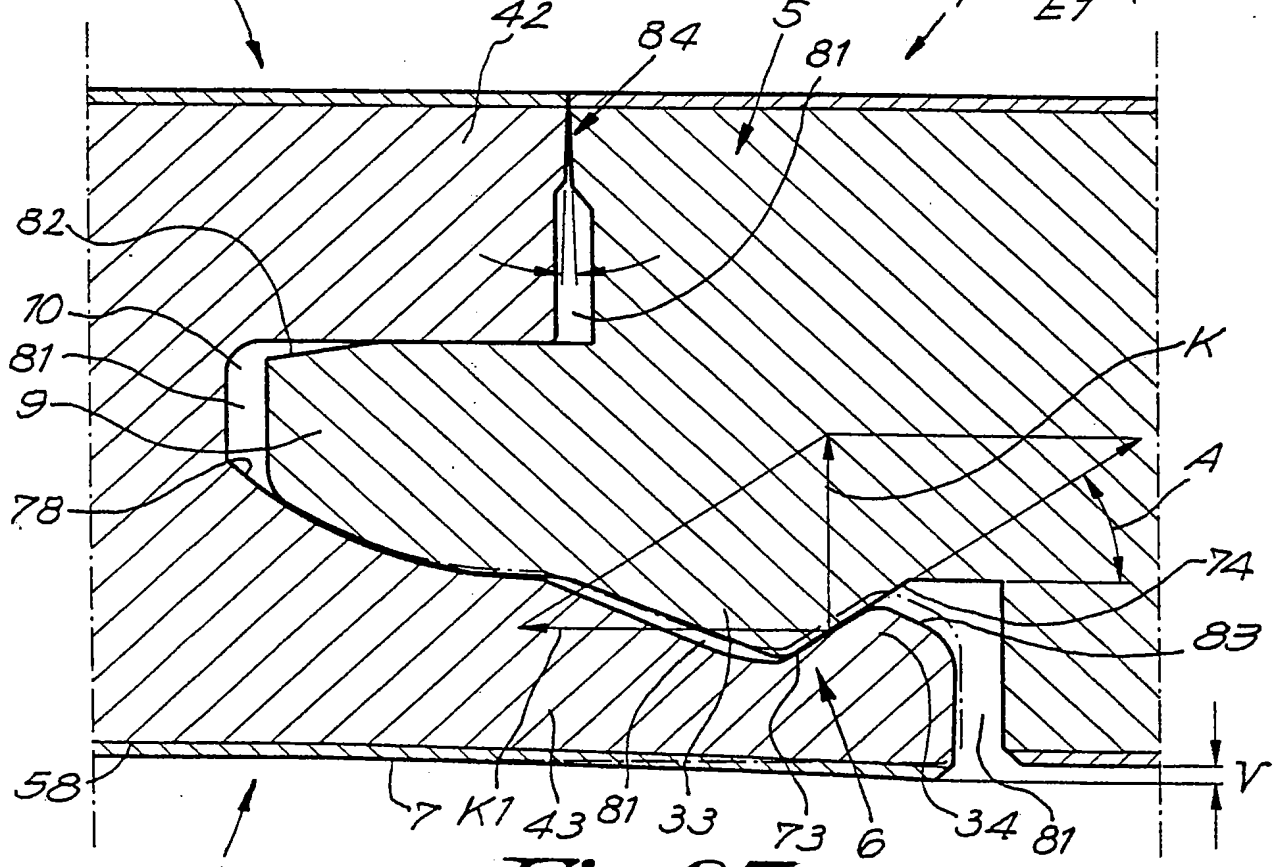
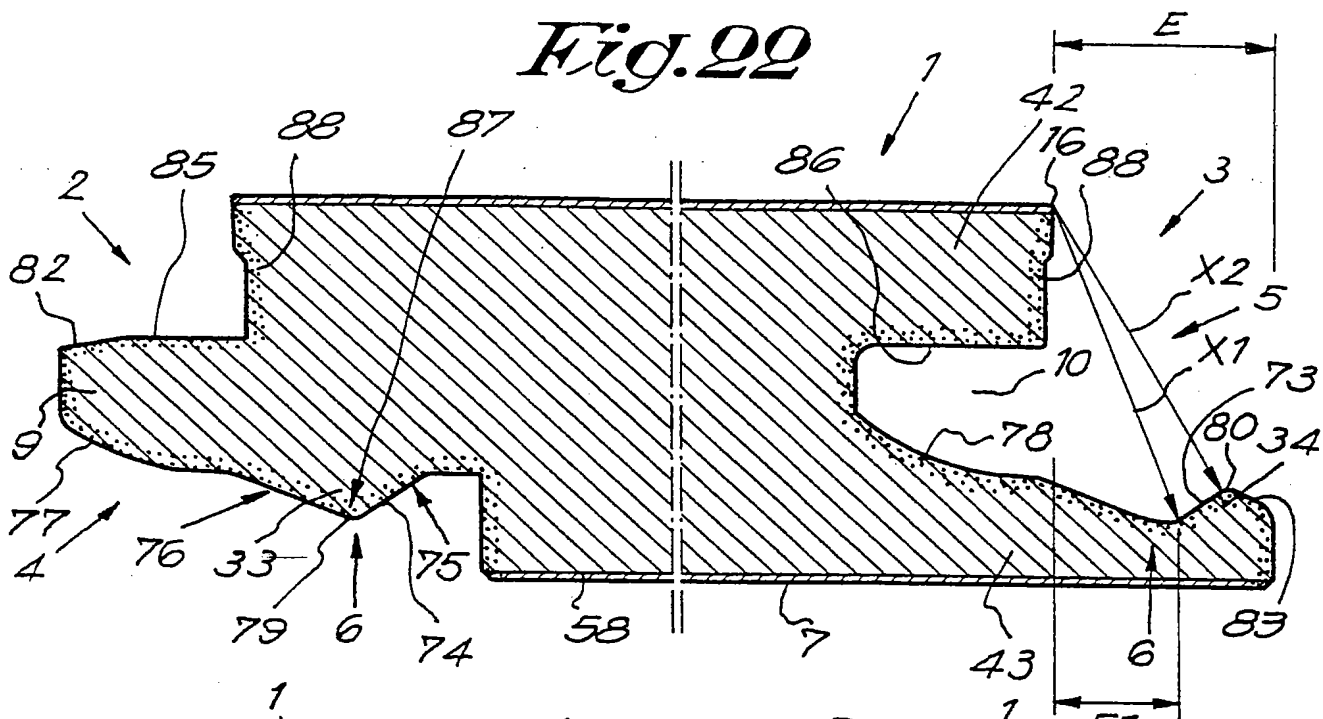


Fig. 23



# INTERNATIONAL SEARCH REPORT

5

Intern: l Application No  
PCT/EP 97/03006

**A. CLASSIFICATION OF SUBJECT MATTER**  
IPC 6 E04F15/04 F16B5/00

According to International Patent Classification (IPC) or to both national classification and IPC

**B. FIELDS SEARCHED**

Minimum documentation searched (classification system followed by classification symbols)  
IPC 6 E04F E04B E04C F16B

Documentation searched other than minimum documentation to the extent that such documents are included in the fields searched.

Electronic data base consulted during the international search (name of data base and, where practical, search terms used)

**C. DOCUMENTS CONSIDERED TO BE RELEVANT**

Category *	Citation of document, with indication, where appropriate, of the relevant passages	Relevant to claim No.
A	GB 2 256 023 A (MAGNET HOLDING LTD.) 25 November 1992 cited in the application  see page 4, line 22 - page 7, line 14; figures 1-5  ---	1,2,6-9, 11,12, 19,20, 23,24
A	WO 94 01628 A (NIKKEN SEATTLE, INC.) 20 January 1994 cited in the application see page 3, line 22 - page 5, line 35; figures 1-5  ---	1-5,10, 21,23,24
A	DE 30 41 781 A (TERBRACK KUNSTSTOFF GMBH & CO KG) 24 June 1982 cited in the application see page 8, line 1 - page 10, line 13; figures 1-12  ---	1,2,7,9, 11,18, 23,24
	-/--	

Further documents are listed in the continuation of box C.

Patent family members are listed in annex.

\* Special categories of cited documents :

- \*A\* document defining the general state of the art which is not considered to be of particular relevance
- \*E\* earlier document but published on or after the international filing date
- \*L\* document which may throw doubts on priority claim(s) or which is cited to establish the publication date of another citation or other special reason (as specified)
- \*O\* document referring to an oral disclosure, use, exhibition or other means
- \*P\* document published prior to the international filing date but later than the priority date claimed

- \*T\* later document published after the international filing date or priority date and not in conflict with the application but cited to understand the principle or theory underlying the invention
- \*X\* document of particular relevance; the claimed invention cannot be considered novel or cannot be considered to involve an inventive step when the document is taken alone
- \*Y\* document of particular relevance; the claimed invention cannot be considered to involve an inventive step when the document is combined with one or more other such documents, such combination being obvious to a person skilled in the art.
- \*&\* document member of the same patent family

Date of the actual completion of the international search  
  
18 September 1997

Date of mailing of the international search report  
  
25.09.97

Name and mailing address of the ISA  
European Patent Office, P.B. 5818 Patentaan 2  
NL - 2280 HV Rijswijk  
Tel. (+31-70) 340-2040, Tx. 31 651 epo nl,  
Fax: (+31-70) 340-3016

Authorized officer  
  
Ayiter, J



## INTERNATIONAL SEARCH REPORT

Internat. Application No

PCT/EP 97/03006

C.(Continuation) DOCUMENTS CONSIDERED TO BE RELEVANT		
Category *	Citation of document, with indication, where appropriate, of the relevant passages	Relevant to claim No.
A	DE 35 44 845 A (LIEBICH) 19 June 1987 cited in the application see column 7, line 47 - column 13, line 10; figures 1-5 ---	1,7,9, 10,24-26
A	GB 424 057 A (SMITH) 14 March 1935 cited in the application  see the whole document ---	1,4,7,9, 10, 23-26,28
A	GB 2 117 813 A (OSTROVSKY) 19 October 1983 cited in the application see page 2, line 41 - page 3, line 81; figures 1,2 -----	1,9,11

# INTERNATIONAL SEARCH REPORT

information on patent family members

Intern al Application No <b>PCT/EP 97/03006</b>
--

6

Patent document cited in search report	Publication date	Patent family member(s)	Publication date
GB 2256023 A	25-11-92	NONE	
WO 9401628 A	20-01-94	US 5295341 A	22-03-94
DE 3041781 A	24-06-82	NONE	
DE 3544845 A	19-06-87	NONE	
GB 424057 A		NONE	
GB 2117813 A	19-10-83	NONE	